

## AEROSPACE AND DEFENSE

# Airbus Helicopters

Helicopter manufacturer uses Simcenter Amesim to minimize time and costs for certifying airworthiness

### Product

Simcenter

### Business challenges

Define hydraulic circuit architecture for the entire helicopter, especially in hot conditions

Assess the need for an additional cooling system

Meet short development timeline to maintain competitiveness

### Keys to success

Use Simcenter Amesim to assess hydraulic circuit performance early on

Refine parameters to tune the model for normal mode and failure cases

Understand the thermal influence of the neighboring systems on the hydraulic circuit

### Results

Enhanced competitiveness by minimizing costs and time for certifying airworthiness

Received accurate results on stationary helicopter (+/-5 degrees Celsius difference between simulation and test results)

Performed simulations on several failure case modes

### Siemens Digital Industries Software solution enables Airbus Helicopters to predict thermal behavior of hydraulic systems under any flight conditions

#### Navigating the airworthiness certification process

Airbus Helicopters strives to provide the most efficient solutions to its customers who serve, protect, save lives and safely carry passengers in demanding environments. Its helicopters are in service across more than 150 countries, performing nearly every type of vertical flight task imaginable. The company's product line offers the full spectrum of rotary-wing aircraft solutions for civil, government, military, law enforcement and combined private/public uses.

To earn an airworthiness certificate issued by a national authority, Airbus Helicopters, like all other aircraft makers, must make sure its machines and systems comply with a long list of certification specifications. To obtain certification, key aircraft systems – such as hydraulics – must be carefully assessed. Systems must work under any flight conditions and ensure the safety of the pilots, crew and passengers in case of failure.

The thermal management of evaluating hydraulic circuits is part of the check list. First, Airbus Helicopters has to assess the integration of the circuit in the aircraft zones with the thermal impact without exceeding maximum defined temperatures. Further, it has to be certified there is a well-designed and working hydraulic circuit that can support proper flight command functioning even in case of failures (leakage, pump failure, etc.).



Airbus Helicopters H160 prototype in flight testing.

**“The whole circuit is linked to the main rotor actuators and the tail rotor actuator. For that we use Simcenter Amesim and its supercomponent capabilities to design some of our components.”**

Benoit Genot  
Hydraulic and Flight Control Engineer  
Airbus Helicopters

Based on these observations, there are two common problems that engineers must consider: the first one is development time. Indeed, getting certified is a long process. The earlier Airbus Helicopters can obtain certification, the faster it can get to market and the more competitive it can be. The second is the cost of prototypes incurred by test campaigns. So time and cost are a big part of the challenge, and that is something Airbus Helicopters considers when putting together its development programs.

**Predict and verify thermal-hydraulic system performance**

Of course, Airbus Helicopters cannot even consider bypassing the prototype test phase, whether it is for the system or once the system is integrated into the helicopter. Nevertheless, there are means to assess and define the best system architectures early in the development cycle, as well as the thermal management of the full system based on the architecture definition analysis. Employing system simulation enables Airbus Helicopters to predict and evaluate the strategies to maintain the heat balance of an aircraft program.

That’s what Benoit Genot, hydraulic and flight control engineer, and Jean-Baptiste Lopez-Velasco, thermal management expert, and their teams decided to opt for when they were developing the Airbus Helicopters H160, its six-ton, new-generation, medium-sized rotorcraft. They leveraged Siemens’ Simcenter Amesim™ software, part of the Simcenter™ portfolio, to accurately predict and verify the thermal-hydraulic system performance from early stage system sizing to fully integrated design. Their objective was to provide power to the main actuators installed on the helicopter flight domain while designing the hydraulic circuit. This is done under specific conditions, such as not exceeding temperature qualifications in hot conditions that can reach 50 degrees Celsius/122 Fahrenheit in outside air temperature.

“Our first objective was to design a rough architecture of a hydraulic circuit,” says Genot. “Each hydraulic power supply unit is composed of a tank, sensors (temperature/pressure/fluid level), pumps and an emergency pump in case of a failure of one of the main pumps. The whole circuit is linked to the main rotor actuators and the tail rotor actuator. For that we use Simcenter Amesim and its supercomponent capabilities to design some of our components.”

Secondly, it is crucial to understand the thermal influence of the hydraulic system on some of the helicopter parts. Indeed, once integrated into the helicopters, the hydraulic circuit mainly covers the upper deck and main gearbox compartment. Around 90 percent of the hydraulic circuit is in this area. That is what Lopez-Velasco analyzes: “Based on the first scheme of the hydraulic system (modeled according to normal and failure cases conditions), we can start the thermal modeling using Simcenter Amesim,” says Lopez-Velasco. “One of the questions that Simcenter Amesim helps us clarify is whether it is required to cool the fluid – in that case we

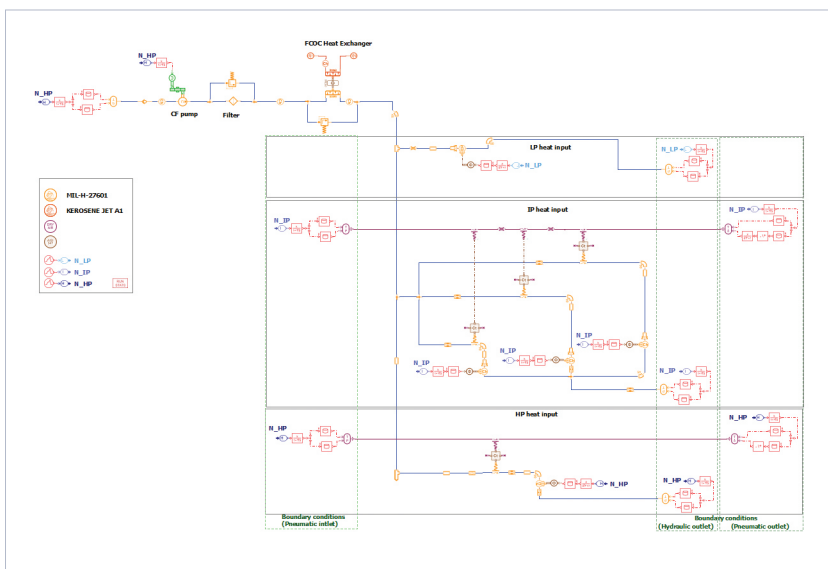

Simcenter Amesim thermal-hydraulic model.

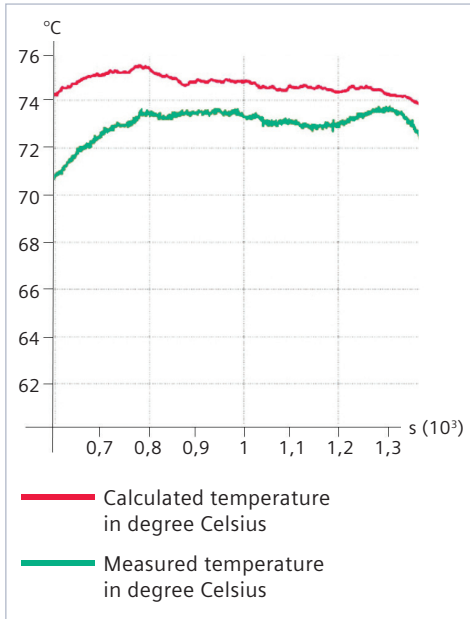

Comparison of stationary oil temperature: simulation vs test.

need to use a heat exchanger. Then during the development there are several loops of calculation to refine the model.”

#### Saving time on test campaigns

“Of course, tests remain mandatory for modeling construction and validation,” says Lopez-Velasco. “Using Simcenter Amesim for system simulation enables us

to anticipate model architecture so we can save time on the test campaigns because our model is already fine-tuned.”

During test campaigns, Airbus Helicopters teams test the system in normal and failure modes. The measurements are done at different levels. They assess oil temperature, ambient temperature, velocities, pressures and flowrate. In addition to comparing the test and simulation result, the idea is also to refine the parameters of the simulation model based on the test results. The purpose is to make the model as true as possible to the physical version of the product.

In this case, Genot and Lopez-Velasco reached an accurate result because the difference between the Simcenter Amesim modeling and the test bench results only

**“One of the questions that Simcenter Amesim helps us clarify is whether it is required to cool the fluid – in that case we need to use a heat exchanger.”**

Jean-Baptiste Lopez-Velasco  
Thermal Management Expert  
Airbus Helicopters



Full dynamics test bench.



Modeling with Simcenter Amesim permits us to anticipate the design and architecture freeze of the hydraulics systems (routing, tank, heat exchanger) to secure the development cost and planning.”

Benoit Genot  
Hydraulic and Flight Control Engineer  
Airbus Helicopters

### Solutions/Services

Simcenter Amesim  
siemens.com/  
simcenter-amesim

### Customer's primary business

Airbus strives to provide the most efficient solutions to its customers who serve, protect, save lives and safely carry passengers in demanding environments. Its helicopters are in service across more than 150 countries, performing nearly every type of vertical flight task imaginable. Airbus Helicopters offers the full spectrum of rotary-wing aircraft solutions.  
www.airbus.com/helicopters.html

### Customer location

Marignane  
France

varied by +/-5 degrees Celsius while the aircraft was stationary.

"Modeling with Simcenter Amesim permits us to anticipate the design and architecture freeze of the hydraulics systems (routing, tank, heat exchanger) to secure the development cost and planning," says Genot.

In the future, Genot and Lopez-Velasco plan to study different weather cases, work on transient calculations (not only for stationary analyses) and integrate a real-time platform with Simcenter Amesim.



Hydraulic actuator test bench.



Using Simcenter Amesim for system simulation enables us to anticipate model architecture so we can save time on the test campaigns because our model is already fine-tuned."

Jean-Baptiste Lopez-Velasco  
Thermal Management Expert  
Airbus Helicopters

### Siemens Digital Industries Software

Americas 1 800 498 5351  
Europe 00 800 70002222  
Asia-Pacific 001 800 03061910  
For additional numbers, click [here](#).

[siemens.com/software](https://www.siemens.com/software)

© 2019 Siemens. A list of relevant Siemens trademarks can be found [here](#). Other trademarks belong to their respective owners.  
74166-D13 1/19 C