

DIGITAL INDUSTRIES SOFTWARE

Simcenter 3D for motion simulation

Create, validate and share mechanism designs with a fully integrated platform

Solution benefits

Accurately predict complex mechanism behavior

Quickly build and maintain motion models using an integrated CAE environment

Integrate systems and controls to simulate mechatronic systems

Use add-on modules to simulate specific applications like tires or drivetrains

Seamlessly share and use motion simulation results across Simcenter 3D as input for other types of CAE applications

Simcenter™ 3D software offers modeling and simulation that helps engineers understand and predict the functional behavior of mechanisms. It delivers a complete and robust set of capabilities to support all aspects of advanced dynamic, static and kinematic motion simulation. The early use of motion simulation is key to evaluating mechanism performance to increase design confidence and reduce risks.

Providing a platform for multidiscipline simulation

The Simcenter 3D motion solution is part of a larger, integrated multidiscipline simulation environment with the Simcenter 3D Engineering Desktop at the core for centralized pre-/postprocessing

for all Simcenter 3D solutions. Simcenter is part of the Siemens Xcelerator business platform of software, hardware and services. This integrated environment helps you to achieve faster computer-aided engineering (CAE) processes and streamline multidisciplinary simulations. It integrates motion and other disciplines like finite element models for flexible body analysis as well as connections with acoustics for gear whine analysis.



Motion

SIEMENS

[siemens.com/simcenter3d](https://www.siemens.com/simcenter3d)

Simcenter 3D for motion simulation

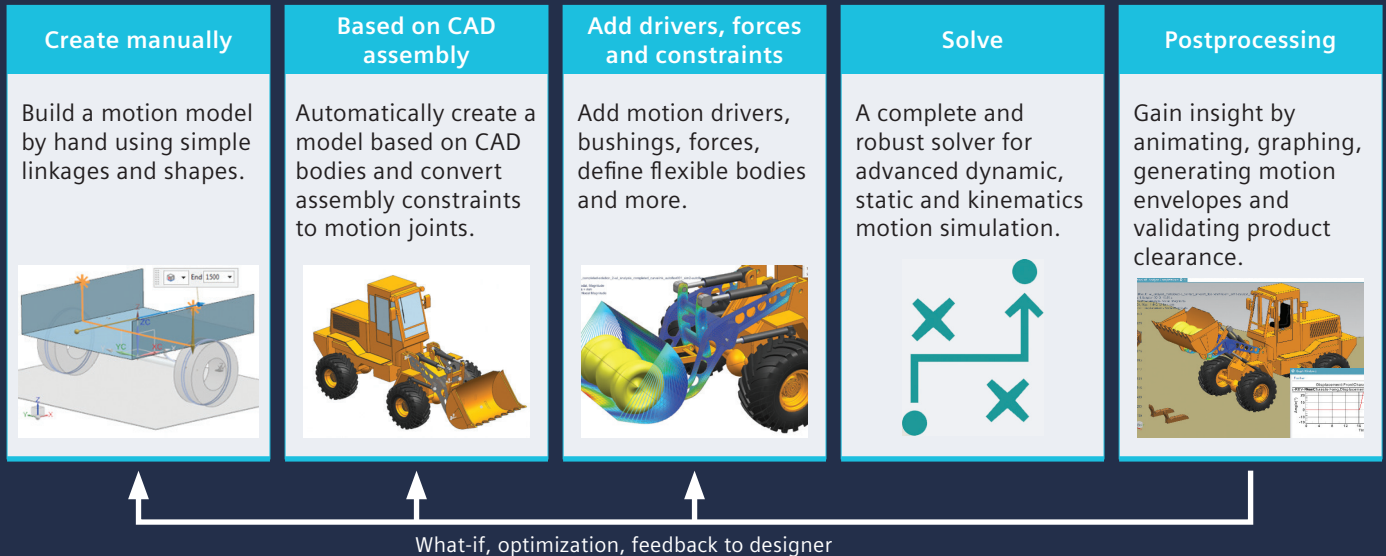

A motion simulation solution for both analysts and designers

Designers and analysts typically approach motion simulation from two different perspectives, where CAD designers start with CAD data, and analysts often start with only the engineering data. Simcenter 3D Motion solutions provide solutions that work for both designers and analysts. Analysts can use Simcenter 3D Motion to create new mechanism models by hand using simple primitive geometry for motion bodies. This helps you understand how a new assembly mechanism might work before applying any detailed geometry. Designers working with computer-aided design (CAD) assembly models during the detailed design stage can quickly convert these assemblies into a working motion model in seconds by converting the geometry bodies into mechanism motion bodies and assembly constraints into corresponding motion joints. This can save designers critical modeling time, so they can begin realizing how geometry will impact the performance of their mechanism.

Accurately predict complex mechanism behavior

The Simcenter 3D Motion solver is built on more than 30 years of proven technology and uses the most advanced numerical multibody solving techniques to deliver fast, stable and robust

simulation. Additionally, it provides accurate results for reaction forces, displacement, velocities and accelerations for rigid and flexible bodies. The loads obtained from the simulation can also be applied to structural analysis and durability, noise and vibration studies.

Integrate systems and controls to simulate mechatronic systems

Simcenter 3D can be integrated with leading control design tools and supports both model exchange and co-simulation methods to solve the mechanical system equations simultaneously with the controller or actuator system equations. This helps you understand how controls will impact the overall mechanism performance.

Seamlessly share results across Simcenter 3D

For certain types of structural, acoustics, vibration and durability analysis, it is critical to understand the loading conditions for the part or assembly being analyzed. You can seamlessly transfer loading conditions calculated with Simcenter 3D Motion solutions to the Simcenter 3D Engineering Desktop for use in other simulation applications. This will greatly improve productivity for you or your extended simulation team.

Industry applications

Understanding the operating environments for intricate mechanical systems – such as photocopiers, sliding sunroofs and wing flaps – can be challenging. Motion simulation calculates the reaction force, torque, velocity, acceleration and more for mechanical systems to allow you to study a broad range of product behaviors.

Automotive and transportation

Cars include a wide variety of mechanisms that impact vehicle performance and driver comfort. You can use Simcenter 3D to evaluate transmission, suspension and tire performance as well as mechanisms such as closures (sunroof), seats and doors.

Aerospace and defense

Aerospace customers use Simcenter 3D Motion to evaluate landing-gear performance as well as wing-flap mechanisms.

Marine

Using Simcenter 3D can help engineers simulate how rudder systems perform in addition to other on-board mechanisms, like cranes on a cargo ship.

Industrial machinery

Industrial machines move constantly, from complex production machines to robots and conveyors. Machine developers can use Simcenter 3D to enable their machines perform as expected.

Electronics

Electronics often have complex, well controlled moving mechanisms. Simcenter 3D can help you simulate the motion of photocopiers, scanners, disk drives and more.

Consumer products

Washing machines, dishwashers and toys all have mechanisms that end users rely on to meet their needs. Simcenter 3D can help you efficiently engineer these mechanisms.

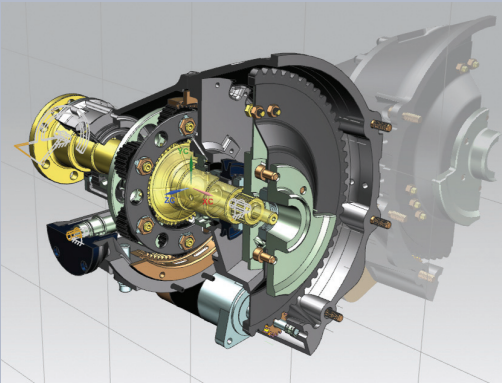
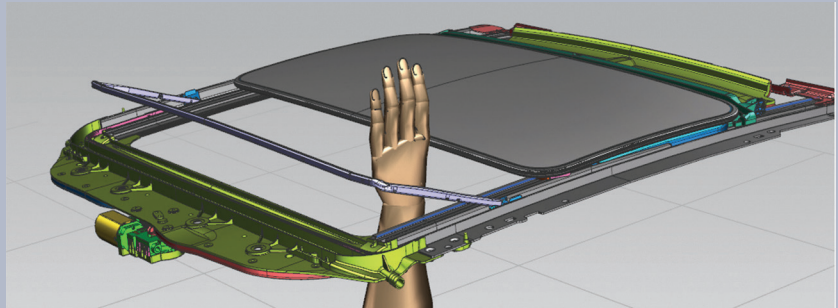
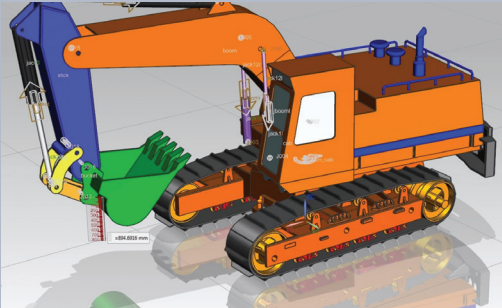

Rigid body
Flexible body
Co-simulation with controls
Interference checking
Drivetrain

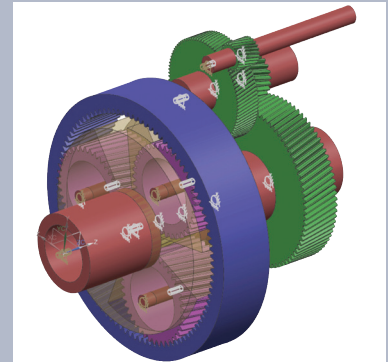

Simcenter 3D

Motion Modeling

Simcenter 3D Motion Modeling software provides multibody pre- and postprocessing capabilities to model, evaluate and optimize mechanisms. The module delivers a complete, yet simple-to-use set of capabilities to study the complex aspects of kinematics and dynamics during product development in industries such as aerospace, automotive, industrial machinery and electronics.

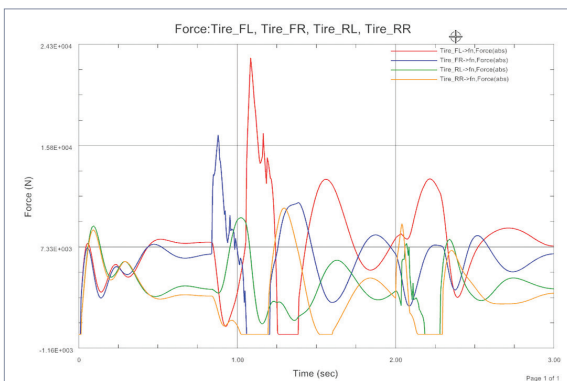
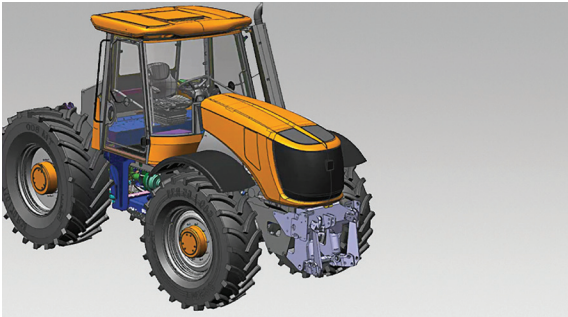

Module benefits

- Reduce expensive physical prototypes by using motion simulation to understand mechanism performance
- Gain insight into the kinematic and dynamic performance of a mechanism by animating, graphing and generating motion envelopes and validating product clearance

Key features

- Quickly convert CAD geometry and assemblies into fully functional motion models
- Seamlessly transfer motion results to other Simcenter 3D applications for structural analysis, durability, acoustics and more
- Includes a natural and direct interface to Simcenter Amesim™ software for accurate behavior of electronics, hydraulics and control components throughout the system

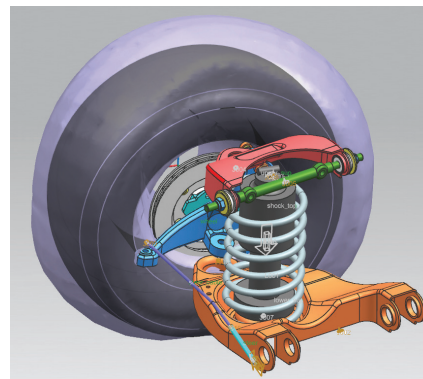

Simcenter 3D

Motion solver

Simcenter 3D Motion solver helps engineers predict and understand the functional behavior of parts and assemblies. This multibody dynamic solver delivers a complete and robust set of capabilities to solve all aspects of advanced dynamic, static and kinematic motion simulation.

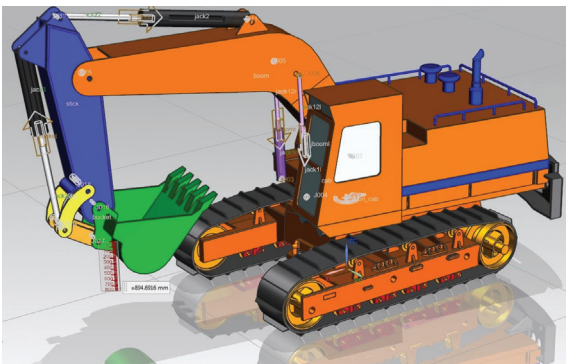
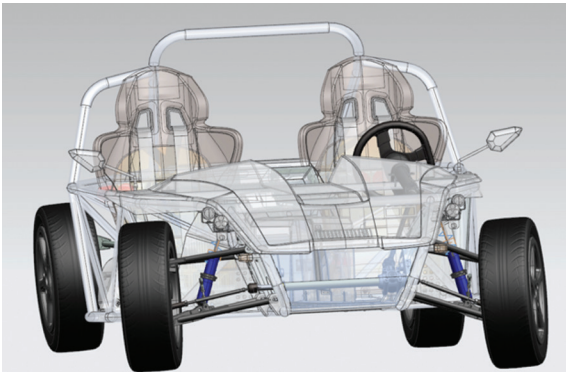

Module benefits

- Achieve highly accurate simulations (displacements, velocities, accelerations, reaction forces, flexible body results) using advanced multibody dynamics solving techniques
- Reduce costly physical prototypes by using motion simulation to understand mechanism performance

Key features

- Analysis types include kinematic, dynamic, static, quasi-static, time and step, articulation (interactively driven), spreadsheet (driven via a live Excel spreadsheet software table)
- An efficient set of sparse matrix algorithms to solve the linear equations formed in each type of analysis
- Explicit and implicit numerical integrators
- Support for model exchange and co-simulation
- User-defined subroutines
- The Simcenter 3D Motion solver four node allows customers to share solver licenses over multiple cores and machines. It provides the advantage of sharing licenses of some add-on modules across cores and machines

Simcenter 3D

Motion Model Export

Simcenter 3D Motion Model Export is the gateway to exporting models for both effortless model sharing as well as real-time simulation purposes. After the model is exported in the user selected format, the resulting model files can be used without a runtime license on real-time (RT) applications and/or integrated with other multi-physics models. This freedom allows easy sharing and operation of exported Motion models across departments. The ability to reuse existing validated model supports the industry goals to have a single source of modeling.

The exported models are solved using the Simcenter 3D Motion fixed-step Real-Time solver. This allows the reuse of existing and complex models for RT simulators and hardware-in-loop tests that require hard RT solving.

Module benefits

- Re-use Simcenter 3D Motion models in real time instead of recreating multiple models
- Avoid reducing models and maintain the original DOF
- License-free runtime after export to promote model sharing and easy usage

Key features

- Real-time performance is possible
- Fixed step solution
- Flexible body support
- Support for Real-time platforms; Concurrent, dSPACE, Procyon, Windows 64, Linux 64 variants
- Support for FMI
- Support for Matlab Simulink

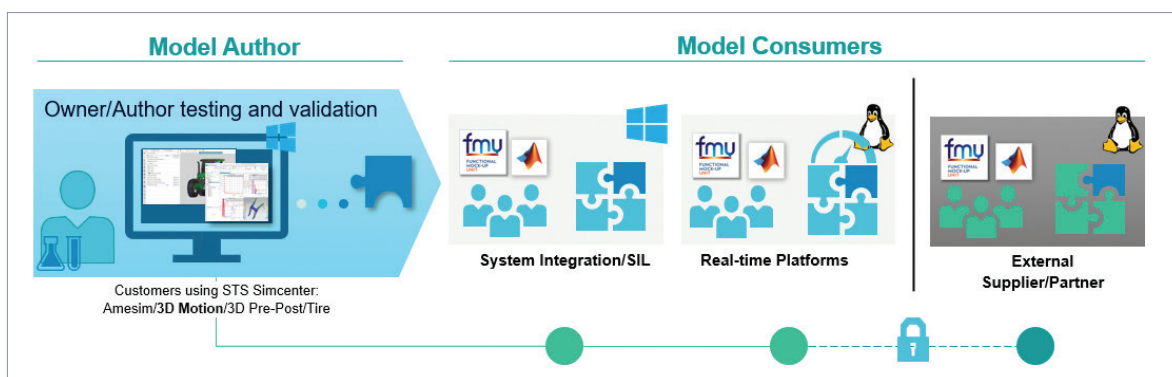

Simcenter 3D Motion Systems and Controls

Mechanical engineers can easily predict how control systems affect their mechanisms, and control engineers can optimize their system designs with Simcenter 3D Motion Systems and Controls. This module provides a library of control modeling elements for the dynamic simulation of mechatronic systems. Through an interface to the MATLAB® environment and the Simulink® environment, you can easily connect motion models directly with control system designs to co-simulate both the motion and control models simultaneously. Simcenter 3D Motion Systems and Controls also includes a generic cosimulation interface for interfacing with other third- party or inhouse codes as well as a Functional Mockup interface (FMI) that enables you to create FMI units that contain the model structure, variables, parameters, inputs, outputs and functionality of your original model. Then enables you to export/import simulation models between software packages.

Module benefits

- Reduce risks from early design phases and gain engineering insight by correctly simulating the combined mechatronic system
- Design accurate and robust actuators and controllers

Key features

- Embedded library of control modeling elements including 2D graphical view of control block diagram
- Variable step solution
- Support for FMI
- Interface to Simcenter Amesim, MATLAB or Simulink for simulation of full nonlinear mechanical systems, including complex control and actuators

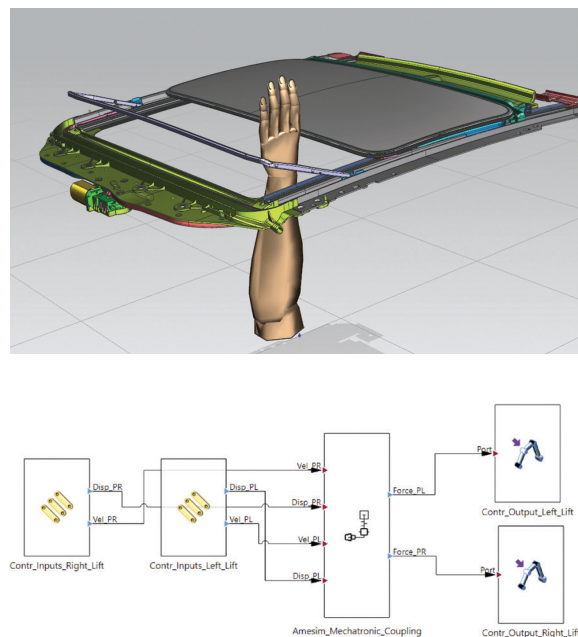
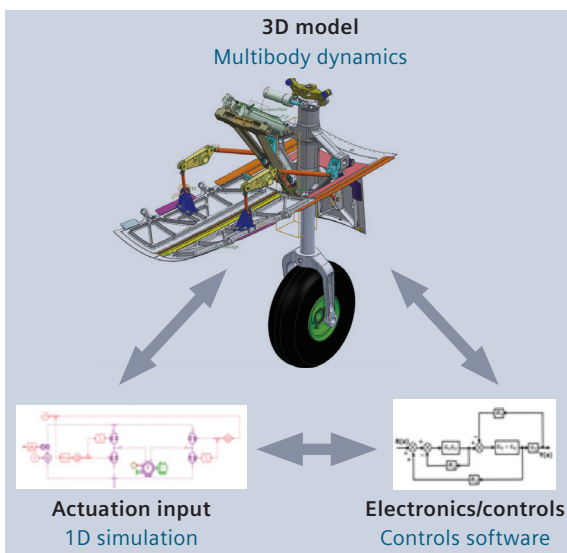

Simcenter 3D

Motion Flexible Body

Using Simcenter 3D Motion Flexible Body helps increase the accuracy of multibody models by considering component deformations when simulating the motion of mechanisms. This approach allows you to combine the standard multibody simulation technology with a representation of body flexibility using a set of deformation modes.

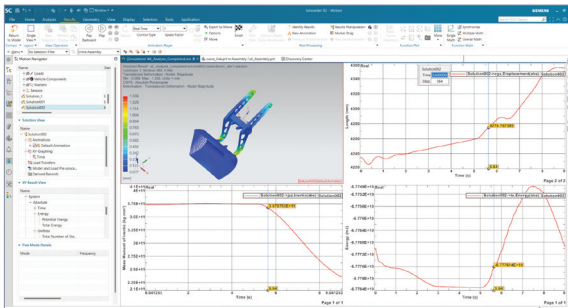
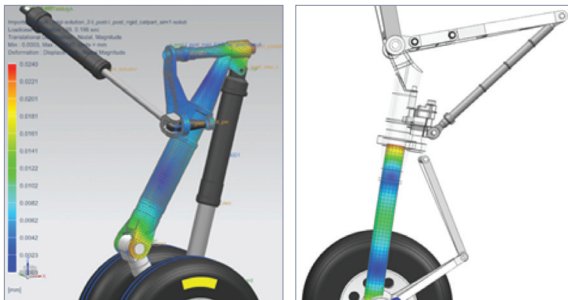

Module benefits

- Increase the accuracy of the predicted motion of mechanisms with flexible components
- Accurately predict the structural behavior of a body based on exact loads from connections in a mechanism

Key features

- Component mode synthesis methods available with multiple FE solvers such as Simcenter Nastran® software, MSC Nastran, ANSYS and Abaqus
- Editing of flexible body properties: mass and moments of inertia, modal damping

Simcenter 3D

Motion Flexible Body Advanced

Using Simcenter 3D Motion Flexible Body Advanced extends modeling by using an automated process to turn existing geometry into a flexible body for motion analysis. It also allows you to model constraints and contact forces applied to flexible bodies.

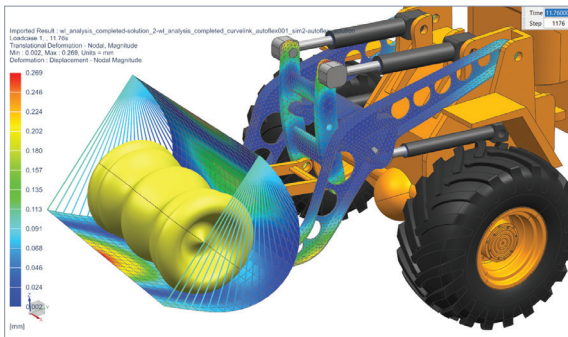

Module benefits

- Simplify the flexible body modeling process with time-saving guided procedures
- Facilitate simulation of distributed loads on flexible bodies due to contacts

Key features

- Automatic flex tool: It takes only a few mouse clicks to go from existing CAD geometry to a complete flexible body with associative finite element (FE) mesh representation and proper boundary conditions based on the connections to the mechanism
- Contact forces on flexible bodies: rigid-to-flex, flex-to-flex
- Point-on-curve constraints extended to flexible curves defined on FE nodes

Simcenter 3D

Motion Standard Tire

Using Simcenter 3D Motion Standard Tire enables you to model any force component generated by a pneumatic tire in contact with a road surface, including normal and vertical, longitudinal and lateral, as well as all resulting moments.

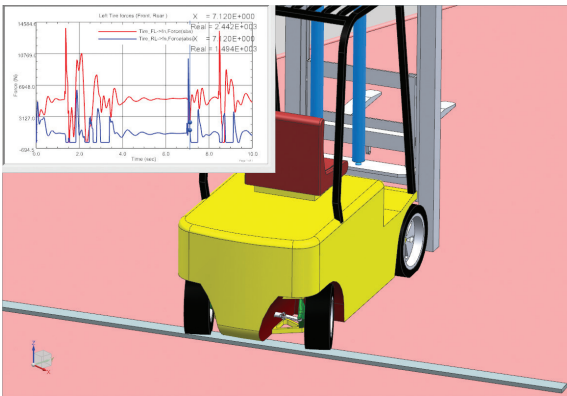

Module benefits

- Accurate prediction of tire-road interactions for CAE based driving dynamics assessment
- Predict ride comfort and handling performance of a vehicle with a limited number of tire and road parameters

Key features

- Access multiple tire force models with a scalable level of detail; suitable models for passenger cars, trucks and buses, agriculture and construction equipment vehicles and landing gear
- Perform high-frequency analyses, such as full-vehicle ride comfort behavior and durability analysis
- Includes three tire formulation models: noninertial, basic and motorcycle

Simcenter Tire

Accurately represent tire performance to predict important vehicle aspects such as directional stability, braking distance, and ride comfort. Using Simcenter Tire enables engineers to effectively and precisely model the highly non-linear tire component. This will allow them to analyze the vehicle behavior better and earlier, reducing development time.

Using Simcenter Tire includes the MF-Tyre/MF-Swift tire model, the MF-Tool tire model parameter tool and tire testing and engineering services. By combining those elements, Simcenter can deliver customized tire modeling methodologies, providing the optimal balance between simulation accuracy and cost-efficiency. The solution has proven success with numerous vehicle OEMs around the globe.

Read the [Simcenter Tire fact sheet](#) for more information.

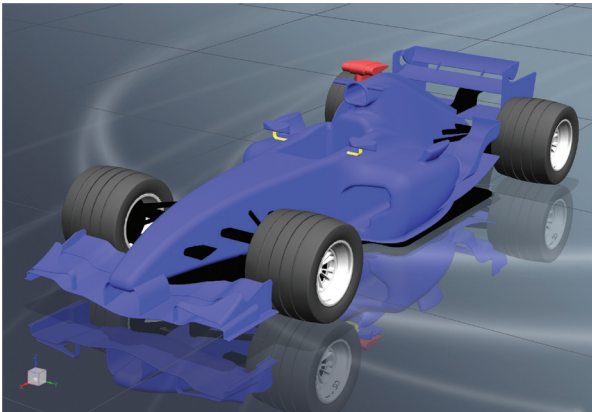

Module benefits

- Simulate tire forces for assessing vehicle handling and controlling prototyping analyses
- Accurately predict vehicle handling behavior, including steady-state cornering, power-off in a turn, lane change, J-turn and more

Key features

- Model the steady-state and dynamic behavior of the tire within a frequency band that covers vehicle handling analyses, as well as control prototyping and rollover simulations
- Simulate vehicle control systems such as antilock braking system (ABS), electronic stability control (ESP), vehicle dynamic control (VDC) and traction control system (TCS)



Simcenter 3D Motion Drivetrain

Simcenter 3D Motion Drivetrain bundles functionality to create transmissions, chains, belts and tracks. This is done through a dedicated interface for transmission creation (Transmission Builder) and the mechanism replication tool (Discrete Drivetrain).

Transmission Builder is an easy to use, in-depth, gearbox specific, multi-body simulation process. That allows engineers to move rapidly from the initial design specifications to an accurate simulation.

The Discrete Drivetrain can replicate a user created mechanical segment along a path. This convenient interface simplifies the modelling of chains, belts and track systems.

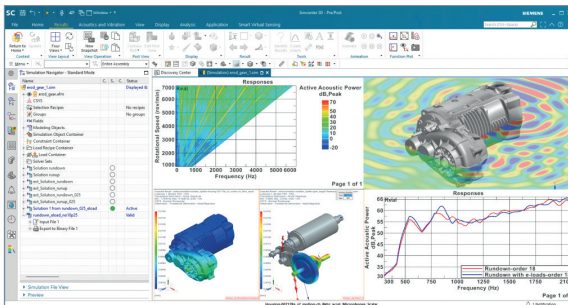

Module benefits

- Automatically create multibody transmission models based on industry standards, reducing model creation time by up to 80 percent
- Perform end-to-end transmission simulation processes in a single environment
- Achieve reliable and fast multibody gear simulations with validated advanced solver methodologies
- Facilitate a robust layout algorithm with a discrete drivetrain to simplify the modeling of chains, belts and tracked systems with customized geometries
- Gain insight into the complex dynamics of chains, belts and tracked systems to improve performance

Key features

- Automated multibody model creation for transmissions based on industry standards
- Manages both cylindrical and spatial gear systems. For cylindrical gears, single, multi-stage spur and helical assemblies both external and internal (such as in planetary systems) gears are supported. For bevel gears, straight bevel and spiral bevel gears are supported (such as in differentials and rear axle drivelines)
- Direct link to Simcenter 3D Acoustics to perform noise, vibration and harshness (NVH) assessment
- Define any pattern body with custom geometry such as chain links and track segments together with their connecting joints and forces
- Define layout components based on user-defined topology
- Predict the transient dynamic response – displacement, velocity, acceleration and loads on all pattern bodies and the related layout components

Capabilities chart

NX and Simcenter 3D Motion capabilities

General capabilities	Specific capabilities												
		NX Motion	Simcenter 3D Motion Modeling	Simcenter 3D Motion solver	Simcenter 3D Motion Systems and Controls	Simcenter 3D Motion Flexible Body	Simcenter 3D Motion Flexible Body Advanced	Simcenter 3D Motion Tire	Simcenter Tire	Simcenter Motion Drivetrain	Simcenter 3D Motion Model export	RT solver Node locked	Simcenter 3D Motion Solver 4-node
Modeling	Import of animation designer, assembly constraint and Tecnomatix® portfolio process simulate kinematics models	•	•										
	Association to part and assembly geometry	•	•										
	Quick creation of primitive graphics	•	•										
	Joints, couplers, constraints	•	•										
	Motion drivers	•	•										
	Spring/damper and bushings	•	•										
	Applied forces	•	•										
	Joint friction	•	•										
	Initial conditions	•	•										
	3D body contact and analytical contact	•	•										
	Submechanisms	•	•										
	Text based elements		•										
Integration with Simcenter Amesim™ software		•											
Postprocessing	Animation	•	•										
	XY graphing	•	•										
	Motion envelope, interference check, point trace, animation camera, load vectors	•	•										
	Capture assembly arrangements during animation	•	•										
	Multiple load case support	•	•										
	Load transfer to Simcenter 3D Engineering Desktop	•	•										
Analysis types and solver capabilities	Multiple output formats (the JT™ data format, VRML, animation movies, etc.)	•	•										
	Static equilibrium	•	+	•									
	Kinematic simulation	•	+	•									
	Dynamic simulation	•	+	•									
	Driver control through articulation and spreadsheet	•	+	•									
	User defined forces and subroutines		+	•									
	Multi-processor batch solver		+	+									•
	Real time solver		+	+						+	•		
Controls	Integration with Matlab		+	+	•								
	Integration with FMI/FMU 1.0 and 2.0		+	+	•								
	Integration with generic co-simulation		+	+	•								
	Control operations		+	+	•								

General capabilities	Specific capabilities	Specific capabilities											
		NX Motion	Simcenter 3D Motion Modeling	Simcenter 3D Motion solver	Simcenter 3D Motion Systems and Controls	Simcenter 3D Motion Flexible Body	Simcenter 3D Motion Flexible Body Advanced	Simcenter 3D Motion Tire	Simcenter Tire	Simcenter Motion Drivetrain	Simcenter 3D Motion Model export	RT solver Node locked	Simcenter 3D Motion Solver 4-node
Flexible bodies	Linear flexible bodies		+	+		•							
	Automatic flexible body creation		+	+		+	•						
	Flexible body contact		+	+		+	•						
	Flexible body point-line constraint		+	+		+	•						
Drivetrain	Powertrain (combustion, tachometer, HD bearings)		+	+					•				
	Chains and Belts – timing or accessory		+	+					•				
	Transmission builder vertical and gear contact		+	+					•				
Vehicles	Tire Modeling of handling and primary ride (<5Hz)		+	+				•	•				
	Tire modeling of secondary Ride (< 25Hz)		+	+					•				
	Tire modeling of Harshness & durability (<100 Hz)		+	+					•				
	Track vehicles		+	+						•			

Legend:

- = included in module
- + = prerequisite

Note: Simcenter 3D Engineering Desktop is a minimum prerequisite for all Simcenter 3D products. Other dependency or prerequisites may apply for individual products.

Siemens Digital Industries Software
siemens.com/software

Americas
 1 800 498 5351

Europe
 00 800 70002222

Asia-Pacific
 001 800 03061910

For additional numbers, click [here](#).

© 2025 Siemens. A list of relevant Siemens trademarks can be found [here](#). Other trademarks belong to their respective owners.